

"TRADER" SERVICE SHEET

635

MURPHY A24

TABLE, CONSOLE and RADIOGRAM



The Murphy A24 table model.

DELAYED amplified automatic volume control is one of the features of the Murphy A24, a 4-valve (plus rectifier) 2-band superhet designed for AC mains of 200-250 V, 50 c/s.

A second model is made for 100 V AC mains, and a third for mains of 25 c/s. The console, A24C, employs a chassis like that in the table model, but uses a larger speaker, while the radiogram, A24RG, employs a modified chassis and a speaker like that in the console. The differences in the radiogram are described under "Radiogram Modifications".

Release date and original prices: 1934 (all models); A24, £14 10s.; A24C, £17; A24RG, £24. Low frequency models 20s. extra.

CIRCUIT DESCRIPTION

Aerial input via coupling coils **L1** (MW) and **L2** (LW) to inductively coupled band-pass filter. Primary coils, **L3** (MW) and **L4** (LW) are tuned by **C29**; secondary coils **L7** (MW) and **L8** (LW) are tuned by **C32**. Coupling by **L6** (MW) and **L5**, **L6** (LW) and **C1**. Image suppression by **C2** and **L9**.

First valve (**V1**, Mazda metallised AC/TP) is a triode-pentode operating as frequency changer with cathode injection coupling. Triode oscillator anode coils **L12** (MW) and **L13** (LW) are tuned by **C35**. Parallel trimming by **C34** (MW) and **C33** (LW); series tracking by **C8** (MW) and **C7**, **C8** (LW).

Reaction coupling by coils **L10** (MW) and **L11** (LW) in cathode circuit.

Second valve (**V2**, Mazda metallised AC/VP1) is a variable-mu RF pentode operating as intermediate frequency amplifier with tuned-primary, tuned-secondary transformer couplings **C36**, **L14**, **L15**, **C37** and **C38**, **L16**, **L17**, **C39**.

Intermediate frequency 117 kc/s.

Diode second detector is part of double diode triode valve (**V3**, Mazda metallised

AC/HLDD). Audio frequency component in rectified output is developed across load resistance comprising resistors **R10**, **R11** and **R12**, and that across **R11**, **R12** is tapped off and passed via AF coupling condenser **C13** to CG of triode section, which operates as AF amplifier. The whole of the DC potential developed across the load resistance is applied via **R13** as GB to the triode control grid.

IF filtering by **C10** in diode circuit, and IF and heterodyne suppression by the tuned filter network, comprising chokes **L18**, **L19** and condensers **C16**, **C17**, **C18**, **C19** in triode anode circuit.

Provision by means of switched jack for the connection of a gramophone pick-up across **R12**, **C11**, via **C12**, **R9**. The triode control grid is returned to cathode, but the diode current will produce a small bias potential for **V3** triode on pick-up operation. Radio is automatically muted by the insertion of the pick-up plug by the opening of switch **S6**, which is associated with the jack and breaks **V2** cathode circuit.

Resistance-capacity coupling by **R17**, **C20** and the manual volume control **R19**, between **V3** triode and pentode output valve (**V4**, Mazda AC/2Pen). Variable tone control by **C22**, **R23** in anode circuit. Provision for connection of a low impedance external speaker across the secondary of the output transformer **T1**.

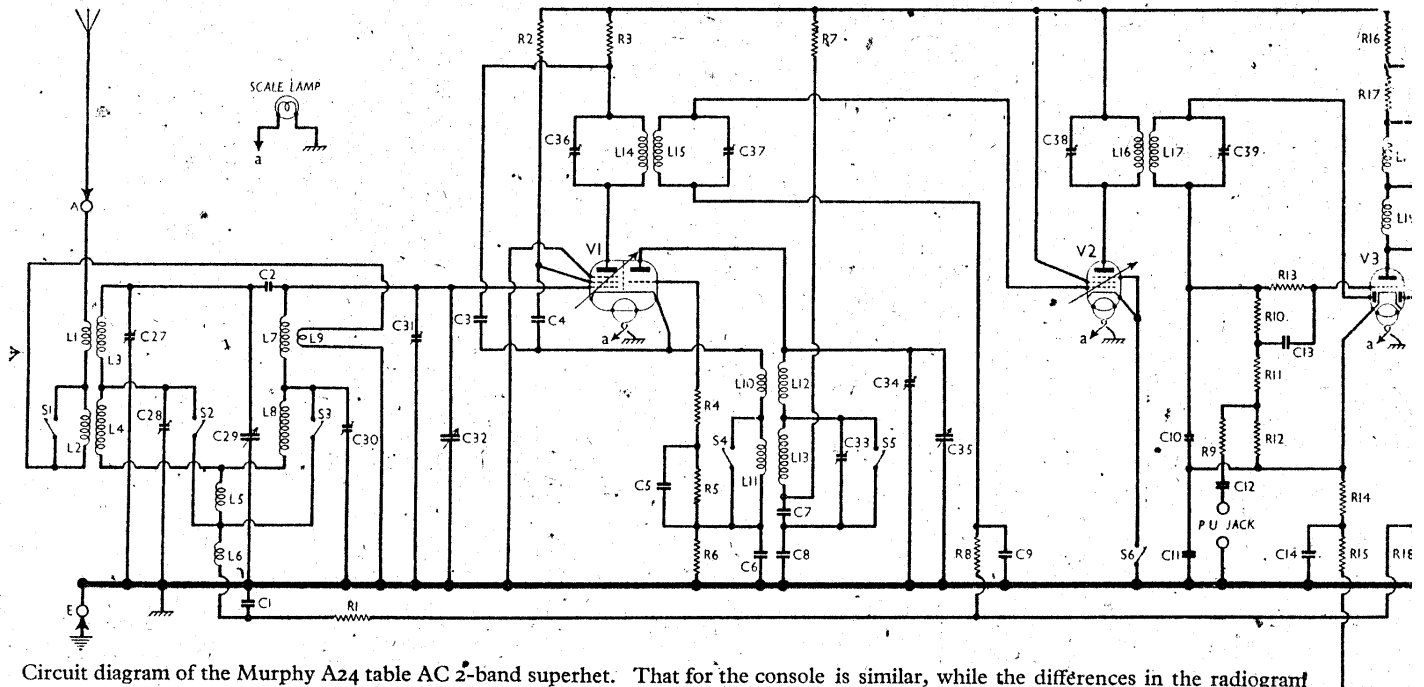

Circuit diagram of the Murphy A24 table AC 2-band superhet. That for the console is similar, while the differences in the radiogram are fully described overleaf under "Radiogram Modifications". The chokes and condensers in **V3** triode anode circuit form a heterodyne filter. **V3** triode operates as a variable-mu valve for AVC purposes, the GB applied to it via **R13** depending upon the strength of the carrier. The smoothing circuit is more elaborate than usual, including two chokes, one of which is tuned. **S6**, in **V2** cathode circuit, opens automatically to mute radio when the pick-up plug is inserted.

HT current is supplied by full-wave rectifying valve (V5, Marconi U12). Smoothing by speaker field L21 (in HT negative lead to chassis) and iron-cored choke L22, which is tuned by C26, in conjunction with C24 and electrolytic condensers C23 and C25.

The AVC Circuit

L21 and R22 are connected in series to form a potential divider, the whole of which is negative with respect to chassis. At their junction is connected the earthy end of the AVC diode load resistance R18, via which a fixed negative potential is thus applied to the AVC diode and the AVC line.

A delayed amplified AVC system is obtained by virtue of the application of the DC potential developed across the signal diode load resistance, R10, R11, R12 as GB to V3 triode control grid as previously described. The direct result of this is that V3 triode anode current varies inversely as the strength of the incoming carrier, because the stronger the signal the more negative does the control grid become relative to the cathode.

The cathode is returned via resistors R14, R15 to HT negative, which is something like 100 V below chassis potential, and under no-signal conditions, when V3 triode control grid is at cathode potential, HT current through V3 is at a maximum, and assuming HT negative to be 100 V below chassis, something like 130 V will be dropped along R14, R15. This puts V3 cathode at 30 V positive with respect to chassis.

The AVC diode is returned via its load resistance R18 to the junction of R22 and L21, which is about 3 V negative with respect to chassis, and V1 and V3 receive this via the AVC line as fixed GB.

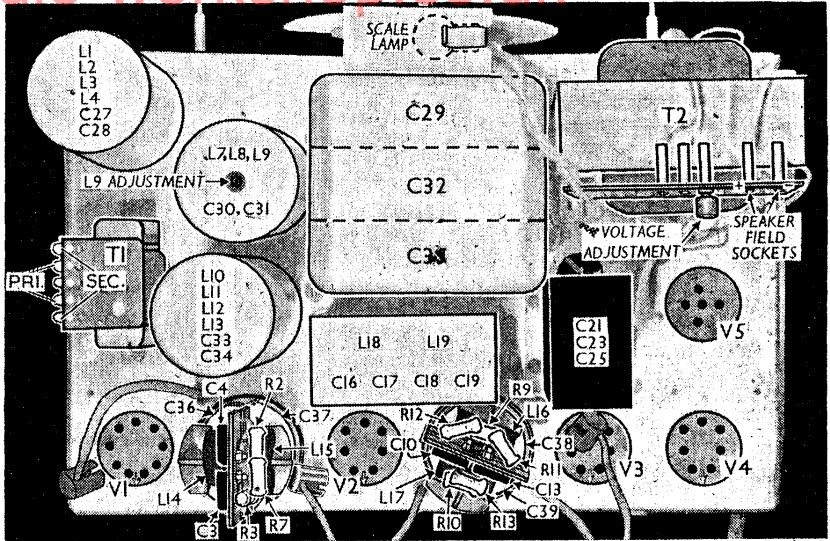

Plan view of the chassis. The adjustment screw for L9 is sunk well down below the top of the L7-L9 can. The screening cans of the IF transformers have been removed. In this illustration to permit a view of the assemblies inside them.

As the cathode is therefore about 33 V positive with respect to the AVC diode, no diode current will flow. When, however, a signal arrives, V3 control grid potential moves in a negative direction, causing a fall in HT current through R14, R15 and reducing the positive potential of the cathode. No appreciable change occurs in the AVC line voltage until the strength of the signal is such that the cathode potential falls below that of the AVC diode; that is, when the diode

is more positive than the cathode. At this point diode current begins to flow, and as the impedance of the diode is low and that of R18 is high, the diode, and consequently the AVC line potential, follows the potential of the cathode, becoming more and more negative as the signal strength increases. This negative potential is passed via the AVC line to the two controlled valves, giving automatic volume control.

COMPONENTS AND VALUES

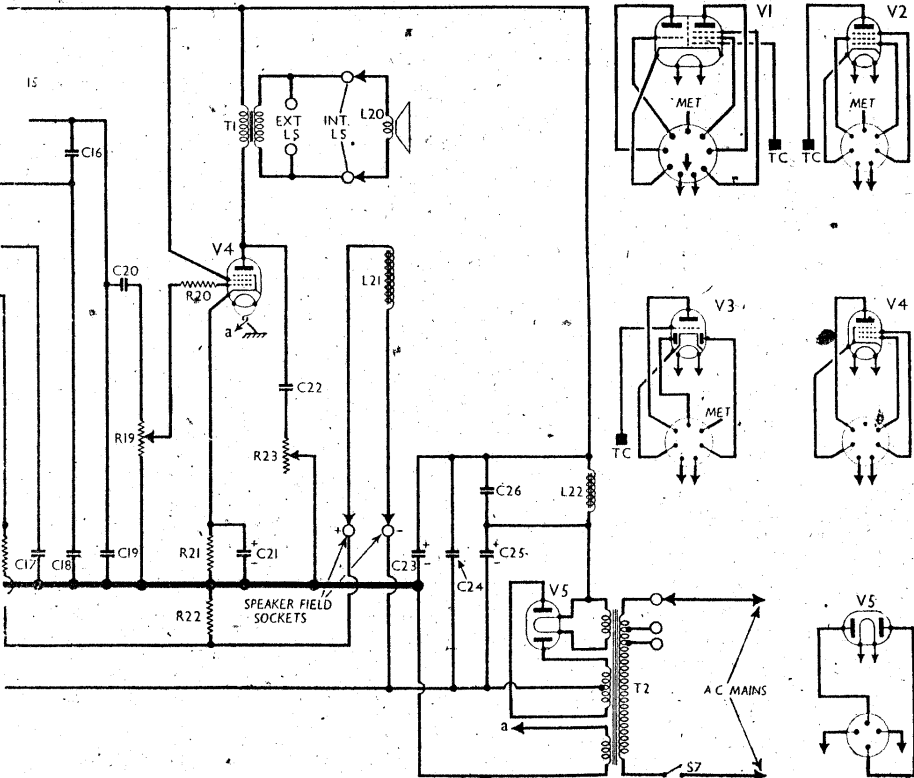

CONDENSERS		Values (μF)
C1§	V1 pent. CG decoupling	0-1
C2	Part image suppressor	0-000002
C3	V1 pent. anode decoupling	0-002
C4	Part of mixer coupling	0-001373
C5	V1 osc. CG condenser	0-0003
C6§	V1 cathode by-pass	0-1
C7	Osc. circuit LW tracker	0-001373
C8	Osc. circuit MW tracker	0-002
C9§	V2 CG decoupling	0-1
C10	IF by-pass	0-00005
C11§	V3 cathode decoupling	1-0
C12	PU coupling condenser	0-05
C13	AF coupling to V3 triode	0-002
C14§	V3 cathode decoupling	1-0
C15§	V3 triode anode decoupling	3-0
C16	Heterodyne and IF filter condensers	0-001373
C17		0-002
C18		0-003
C19		0-001
C20	AF coupling to V4	0-1
C21*	V4 cathode by-pass	50-0
C22	Part variable tone control	0-025
C23*	HT smoothing condensers	3-0
C24§		1-0
C25*		4-0
C26§		0-13
C27§	B-P pri. MW trimmer	0-00007
C28†	B-P pri. LW trimmer	0-00007
C29†	Band-pass pri. tuning	0-0005
C30†	B-P sec. LW trimmer	0-00007
C31†	B-P sec. MW trimmer	0-00007
C32†	Band-pass sec. tuning	0-0005
C33†	Osc. circuit LW trimmer	0-00007
C34†	Osc. circuit MW trimmer	0-00007
C35†	Oscillator circuit tuning	0-0005
C36†	1st IF trans. pri. tuning	0-00014
C37†	1st IF trans. sec. tuning	0-00014
C38†	2nd IF trans. pri. tuning	0-00014
C39†	2nd IF trans. sec. tuning	0-00014

* Electrolytic. † Variable. ‡ Pre-set. § In component assembly unit.

RESISTORS		Values (ohms)
R1\$	V1 pent. CG decoupling	250,000
R2	V1 5G HT feed	20,000
R3	V1 pent. anode HT feed	7,500
R4	V1 osc. CG stabiliser	3,200
R5	V1 osc. CG resistor	50,000
R6\$	V1 fixed GB resistor	700
R7	V1 osc. anode HT feed	100,000
R8\$	V2 CG decoupling	250,000
R9	PU feed resistor	99,000
R10	V3 signal diode load resistors	1,000,000
R11		500,000
R12		99,000
R13	V3 triode CG resistor	2,000,000
R14\$	AVC resistors	30,000
R15\$		33,000
R16\$		7,000
R17	V3 triode anode load	30,000
R18\$	V3 AVC diode load	250,000
R19	Manual volume control	50,000
R20	V4 grid stopper	700
R21	V4 GB resistor	150
R22\$	AVC line bias resistor	55
R23	Variable tone control	50,000

\$ In component assembly unit.

OTHER COMPONENTS		Approx. Values (ohms)
L1	Aerial coupling coils	1.0
L2		7.0
L3		5.0
L4	Band-pass primary coils	12.0
L5		2.75
L6		0.75
L7	Band-pass secondary coils	5.0
L8		12.0
L9		0.25
L10	Image suppressor coil	1.0
L11		2.5
L12		4.0
L13	Osc. MW tuning coil	8.5
L14		40.0
L15		40.0
L16	1st IF trans.	40.0
L17		40.0
L18		40.0
L19	Heterodyne and IF filter coils	370.0
L20		450.0
L21		2,250.0
L22	Speaker speech coil	2.0
L23		2,250.0
L24		315.0
T1	Output trans.	650.0
T2		0.25
T3		29.0
T4	Mains	0.6
T5		0.6
T6		510.0
S1-S5	Waveband switches	—
S6	PU jack-switch	—
S7	Mains switch	—

VALVE ANALYSIS

Valve voltages and currents given in the table below are those quoted in the makers' manual. They represent conditions to be expected in the average receiver when it is operating with the mains voltage adjustment properly set, but with no signal input.

Voltages were measured on the 250 V scale of a meter having a resistance of 1,000 ohms per volt, or a total resistance of 250,000 Ω.

The voltages and current of V3 vary

Valve	Anode Voltage (V)	Anode Current (mA)	Screen Voltage (V)	Screen Current (mA)
V1 AC/TP	195	3.5	190	1.3
	Oscillator	1.5		
V2 AC/VP1	55	9.0	225	3.0
V3 AC/HLDD	130	2.4	—	—
V4 AC/2Pcn	210	25.0	225	6.0
V5 U1E	240†	—	—	—

† Filament to chassis, DC. Either anode, to HT negative (negative side of C25), 350V AC.

considerably with the strength of a signal, and whereas the anode voltage is given in the table as 130 V at 2.4 mA, this becomes 185 V with a strong signal, with the current at 1.4 mA. The cathode voltage of this valve varies between +30 V at no signal and -12 V for a strong signal, as measured from chassis. If valve adaptors are used to measure currents, L15 should be short-circuited inside the coil can when measuring V2 currents, in order to prevent the valve from oscillating.

DISMANTLING THE SET

Removing Chassis.—Remove the four control knobs (concentric domed nuts); withdraw the speech coil plugs from "Int. LS" sockets at rear of chassis, and the two speaker field plugs from their sockets at the top right-hand corner of the mains transformer; remove the three slotted hexagon bolts (with large metal washers) holding the chassis to the bottom of the cabinet.

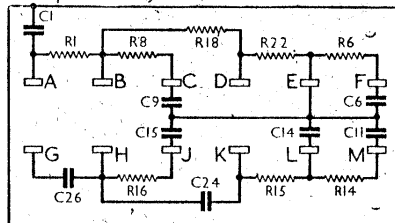

Diagram showing the internal connections of the large enclosed component assembly unit. It is drawn as seen when viewed in the direction of the arrow in the under-chassis view. Tag E is connected to chassis.

Removing Speaker.—Lay cabinet face-downwards on a soft cloth; free the speech coil and field coil leads from the two cleats each holding them to the wooden batten, and from one further cleat each on the sides of the cabinet; remove the 3/16 in. Whitworth hexagon bolt (with clamp plate) from the centre of the batten; withdraw the speaker, together with a dished distance-piece, towards the bottom of the cabinet. When replacing, the connections should be at the bottom. Fit the distance-piece, open side up, to the back of the magnet before sliding into position. The speech coil lead should run through its cleats to the left, and the field coil lead to the right, when viewed from the rear.

GENERAL NOTES

Switches.—S1-S5 are the waveband switches, in a leaf-spring unit beneath the chassis. The switches are individually identified in our under-chassis view. All the switches close on MW, and open on LW (fully clockwise).

S6 is the radio muting switch, associated with the pick-up jack. It opens automatically when the plug is inserted, opening V2 cathode circuit.

S7 is the QMB mains switch, operated by the S1-S5 control spindle. It opens in the fully anti-clockwise (off) position of the control.

Coils.—L1-L4; L7-L9; and L10-L13 are in three screened units on the chassis deck. Their trimmers are in their respective containers, but are reached from beneath the chassis, the positions being indicated in our under-chassis view. The image suppressor adjustment screw,

which controls the position of L9, is reached through a hole in the top of the can.

L5, L6 are the band-pass coupling coils, wound on a small flat unscreened bobbin mounted on the front member beneath the chassis. L5 is the larger winding, in four cans in the middle of the bobbin; L6 is the small winding near the chassis deck.

The IF transformers L14, L15 and L16, L17 are in two further screened units on the chassis deck with their associated pre-set condensers which are reached from beneath the chassis. The cans of all five units on the chassis deck are a tight sliding fit on their bases, and they can all be withdrawn without removing any fixings.

The two IF units each contain several other small components, and these are clearly shown in our plan view, where the cans have been removed before photographing.

L18, L19, in conjunction with condensers C16-C19, form a heterodyne unit with a sharp cut-off at 5,000 c/s in V3 triode anode circuit. All the associated components are mounted in a rectangular metal container behind the gang assembly on the chassis deck.

Scale Lamp.—This is an MES type lamp, with a large clear spherical bulb, rated at 6.2 V, 0.3 A. It can be removed from the chassis for replacement purposes if the clip attached to its holder is drawn away to the right from the rear of the cabinet.

External Speaker.—Four sockets are provided on a panel at the rear of the chassis for the connection of low impedance speakers. Two of the sockets, marked "Int. LS", are for the internal speaker plugs, while the other two, marked "Ext. LS", are for an external speaker which can be muted by the withdrawal of a plug.

Component Assemblies.—Most of the small components are mounted in three assemblies beneath the chassis. Two of the assemblies are formed by mounting components on the two sides of vertical bakelite panels. The third assembly is encased in a metal container, in which are housed eight resistances and eight condensers. This unit is indicated in the centre of our under-chassis view, with the components listed on it. The diagram in column 2 shows the connections between the internal components and the external connecting tags, which are lettered A-H and J-M (I being omitted) to correspond with the markings on the connecting panel. Tag E is earthed. The diagram is drawn as seen when viewed from the left-hand end of the chassis, as seen in our under-chassis view.

Condensers C21, C23, C25.—These are three dry electrolytics, in a single container in our chassis, mounted on the chassis deck. The connections, consisting of four tags and one red flexible lead, emerge beneath the chassis deck. Reading from front to rear, the connections are: 1, positive tag of C25 (4 μF), connected to V5 filament pin; 2, negative tag of C25, connected to centre-tap of T2 H1 secondary, tag K on component assembly panel and negative speaker field socket; 3, red flexible lead, positive side of C21.

connected to **R21** and **V4** cathode; 4, 5, two common tags, positive of **C23**, connected to HT positive line. The negative side of **C12** and **C23** is presumably returned to chassis via the case. The number of the assembly is W1702A.

Chassis Divergencies.—The grid stopper resistance **R20** in **V4** control grid lead was present in our chassis, but was not shown in the makers' diagram. It may have been added after the instrument left the factory, as our receiver was not new, but it is shown in the makers' diagram for the gramophone version of the A24.

The DC resistance of our speaker field winding **L21** was 2,250 Ω , but it was given in the makers' information as 2,400 Ω .

The electrolytic condenser unit W1702A containing **C21**, **C23**, **C25** was not shown in the makers' information. Instead, three separate tubular condensers were shown bolted to the chassis deck by the usual single-hole fixed method.

CIRCUIT ALIGNMENT

IF Stages.—Switch set to MW, and short-circuit **L10** or **L12** to prevent **V1** triode from oscillating. Connect signal generator to control grid (pin 1) of **V2** via a dummy aerial. Feed in a 117 kc/s (2,564.2 m) signal, and adjust **C39** and **C38** in turn for maximum output. Transfer signal generator leads to control grid (top cap) of **V1**, and adjust **C37** and **C36** for maximum output. Remove short-circuit.

RF and Oscillator Stages.—Transfer signal generator leads to **A** and **E** sockets via a suitable dummy aerial. With the gang at maximum, the pointer should cover the line crossing the two scales at the high-wavelength ends of the scales.

MW.—Switch set to MW, tune to 220 m on scale, feed in a 220 m (1,362 kc/s) signal, tune it in, and adjust **C34** for maximum output. Now adjust **C27**, then **C31**, for maximum output, repeating these latter adjustments until no improvement can be obtained.

LW.—Switch set to LW, tune to 1,100 m on scale, feed in a 1,100 m (273 kc/s) signal, and adjust **C33** for maximum output. Now adjust **C28**, then **C30**, for maximum output, repeating these two latter adjustments until no further improvement can be obtained.

Image Suppressor.—Tune receiver to 450 m on scale. Feed in a strong 333 m

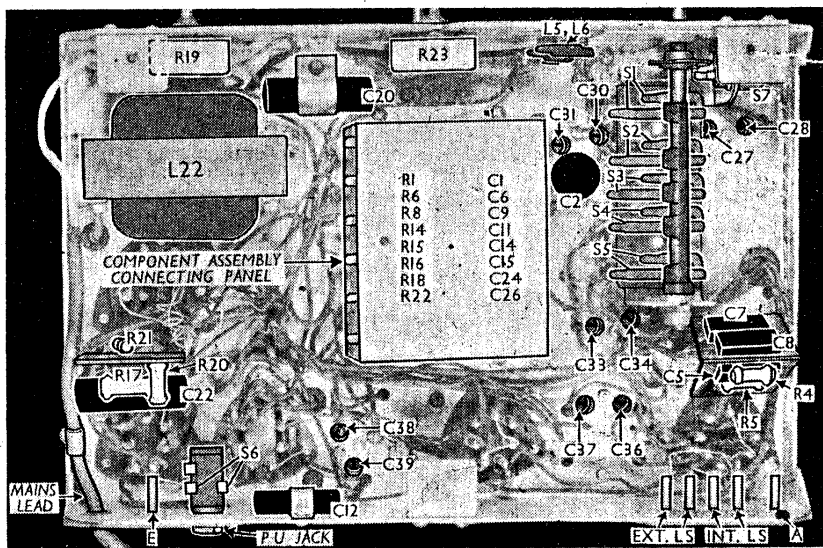

Under-chassis view. The large component assembly is seen in the centre. Its internal connections are shown in the diagram in col. 2 opposite. The two sides of the small assembly on the right are opened out, as though hinged at the top, to show the relative positions of its components.

(900 kc/s) signal, and adjust **L9** (screw in top of **L7**, **L8**, **L9** can) for minimum output. The makers recommend using the speaker as an indicator for this adjustment, instead of an output meter, as an aural indication is more satisfactory than a visual one.

RADIOGRAM MODIFICATIONS

Apart from some modifications associated with the pick-up connections, the chassis of the A24 radiogram is like that in the table model. The differences in the circuit are shown in the diagram below, where the affected part of the circuit overleaf is redrawn to include them.

The pick-up jack is replaced by a two-way single-throw switch, **S8**, **S9** in the diagram. When the set is switched to gram both switches close: **S8** connects up a potential divider consisting of **R12**, **R24** and **R25** across **R14**, a small fraction of the total potential across **R14** being thus applied as GB to **V3** triode. At the same

time the pick-up is connected in circuit via **C12**; **S9** connects the return lead from **L15** to HT negative, thus imposing a high negative potential on the AVC line and paralysing **V1** and **V2** to mute radio.

The additional components are seen in the diagram. Their values are: **R24** and **R25**, each 1,000,000 Ω ; **C40**; 0.05 μ F. The other components, bearing numbers similar to those in the complete diagram overleaf, bear the original values with the exception of **R11** and **R12**, which both become 250,000 Ω . The original **R9** is omitted from the radiogram altogether. The DC resistance of the speaker field **L21** becomes 2,500 Ω , and that of the smoothing choke **L22** 360 Ω .

Physical modifications in the chassis involve the addition of the two switches in a ganged unit, which is mounted on a bracket beneath the chassis near the mains lead entry, and the additional components which are mounted on the same bracket. The switch is operated by the push-pull movement of a lever which runs up from the chassis and projects through the motor board.

Connections between the pick-up and chassis are effected via a panel, carrying four sockets, mounted on the rear right-hand corner of the chassis deck, near the switch lever. Two of the sockets take the pick-up output, and a third the earthing lead from the gram motor and board. The fourth socket is unused.

The remaining differences from the table model are the cabinet, the substitution of a larger speaker, and the addition of a gramophone motor, whose leads are connected across the 200-214 V section of **T2** primary winding. A sheet metal screen covers the back of the cabinet from the base of the chassis upwards, and has a channel pressed in it to accommodate the switch lever. The lower part of the cabinet is open at the rear.

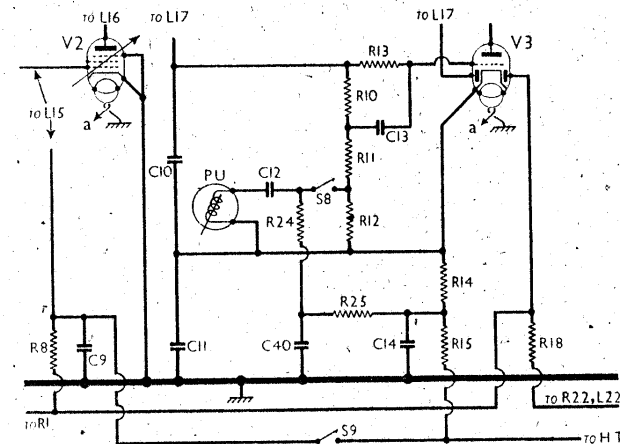

Section redrawn from the main circuit diagram overleaf, showing the modified arrangement in the radiogram version. The points at which it joins the rest of the circuit are labelled accordingly.